



---

# Planning Guide

---

## Residential Elevators

T Rail System with Winding Drum Technology

**Series 021 - MRL**

**022 - RMR**





We are a proud member of the Accessibility Equipment Manufacturers Association. This symbol assures you of our commitment to high quality and accessibility to everyone.



## Waupaca Elevator’s Mission Statement

Our company’s mission is to supply and service products that meet or exceed our customers’ expectations of high quality, value, delivery and longevity. Our success is a direct reflection of our employees’ involvement and commitment to excellence. We strive to continuously improve our products to ensure meeting the future requirements of our customers and facilitate competitive growth.



## CSI 3-Part Specifications

Customize and download CSI 3-Part Specifications by logging on to:

[www.arcat.com](http://www.arcat.com) - specify Waupaca Elevator as the requested manufacturer

[www.waupacaelevator.com](http://www.waupacaelevator.com) - go to “Architect Section” click on linking icon

## Table of Contents

|  |       |
|--|-------|
| Introduction & Planning Steps .....        | 4     |
| Design Features .....                      | 5     |
| Hoistway Layouts .....                     | 6-9   |
| Hoistway Illustrations .....               | 10    |
| Hoistway Specifications .....              | 11    |
| Hoistway Elevation View & Rail Layout..... | 12-13 |
| Machine Room & Controller Location .....   | 14    |
| Elevator Equipment.....                    | 15    |
| Series 021 Mechanical Illustrations.....   | 16    |
| Series 022 Mechanical Illustrations.....   | 17    |



---

# Introduction

This Planning Guide is to be used as a reference to determine parameters of installation and steps taken to achieve a proper elevator installation. This guide may be used by the architect, contractor, dealer or home owner. The information in this guide is intended as an overview. Each installation will have job specific specifications that must be followed. Do not attempt to construct a hoistway on this information.

Elevator installation is to be done by an authorized elevator contractor, and in accordance with installation instructions provided by the manufacturer. Installation must also be in compliance with requirements of the National Electric Code, American Society of Mechanical Engineers safety code, and state and local building codes. Waupaca Elevator's products are designed to meet the requirements of ASME - 17.1 National Elevator Codes for residential elevators. Waupaca Elevator Company, Inc., elevators manufactured and installed under the proper parameters are under warranty for 2 years. Manufacturer assumes no liability for equipment not installed in compliance with these codes.

Waupaca Elevator Company, Inc., reserves the right to modify the design, technical specifications and dimensions of the products shown in this document.

---

# Planning Steps

1. - Locate local dealer and together determine the following:
  - A - Select drive system, car type and design specifications
  - B - Address national, state and local code requirements
  - C - Hoistway size
  - D - Car size, layout and options
  - E - Machine room location and layout (if required)
  - F - Electrical requirements
2. - Obtain and follow site specific field drawings while building hoistway, doorways and any other construction related to the elevator.
3. - Coordinate with dealer to install elevator.

---

## Design Features of :

### T Rail System with Winding Drum Technology

Series: 021 MRL - Machine Roomless

022 RMR - Reduced Machine Room

---

- Rigid Design Built on 8 lb. T Rail System
- Utilizes Proven Winding Drum Technology to Build Reliability
- Durable Cantilever Sling Design
- System Free of Hydraulic Oil
- PLC Control System with Variable Frequency Drive
- Tape Reader Locates Floors with Magnetic Sensor
- Sling Movement Translates Through Roller Wheels Enhancing Ride Quality

# Hoistway Layouts

## Minimum and Maximum Dimensions

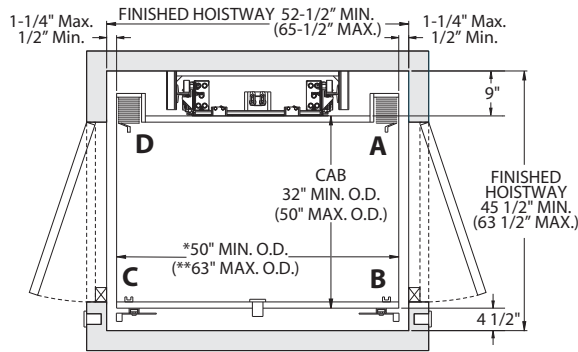

### Minimum

\* Single Opening - 43 - 1/4" O.D. Min.  
(rail is not centered in hoistway)

### Maximum

\*\* Single Opening - 62 - 1/2" O.D. Max.

### NOTE:

- 1) Minimum **DA** dimensions reflect rail centered in hoistway
- 2) Minimum **DA** dimension for car without a gate recess is 37" O.D. (outside dimension)
- 3) Car I.D. (inside dimensions) can not exceed 15 sq. ft. for a 1,000 lb. rated car.

## Car Opening Configurations and Coding

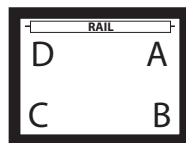
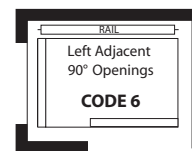
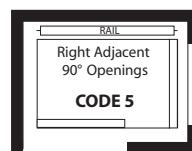
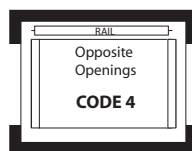
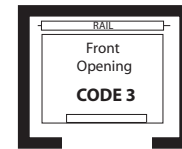
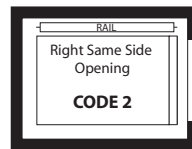
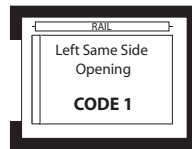

- 1- The DA is the side on which the rail is attached.
- 2- The first letter refers to the attachment location of the gate.
- 3- The second letter refers to the location of the strike plate.
- 4- If present, the third letter "R" denotes a recessed gate.

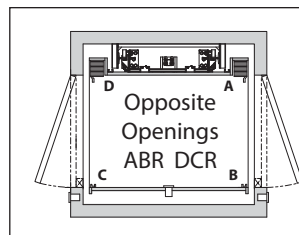

### Example: ABR DCR

|                    |                     |
|--------------------|---------------------|
| First Gate - ABR   | Second Gate - DCR   |
| A- gate attachment | D - gate attachment |
| B - strike plate   | C - strike plate    |
| R - recessed gate  | R - recessed gate   |

# Hoistway Layouts - Series 021 & 022

## Construction Notes:

- Use specified rail backing from architect to frame into wall.
- The hoistway illustrations below show finished dimensions. Finished hoistway dimensions include drywall, plaster and paint.
- A maximum of 3" (see "f" below) are allowed between the closed hoistway door and the outer edge of the landing sill.
- Determine height of hall station by local code.
- Rough frame door in place with an extra inch of space on each side of the door to allow for door installation.

The following examples are of units up to 1,000 lbs. Elevators are illustrated with accordion gates. The following layouts were designed for travel up to 50 feet.

These symbols are listed beside the car size Waupaca Elevator believes to be best suited for use by wheelchair passengers and their accompanying attendant.



Recommended size for wheelchair passenger



Recommended size for both wheelchair and attendant passengers

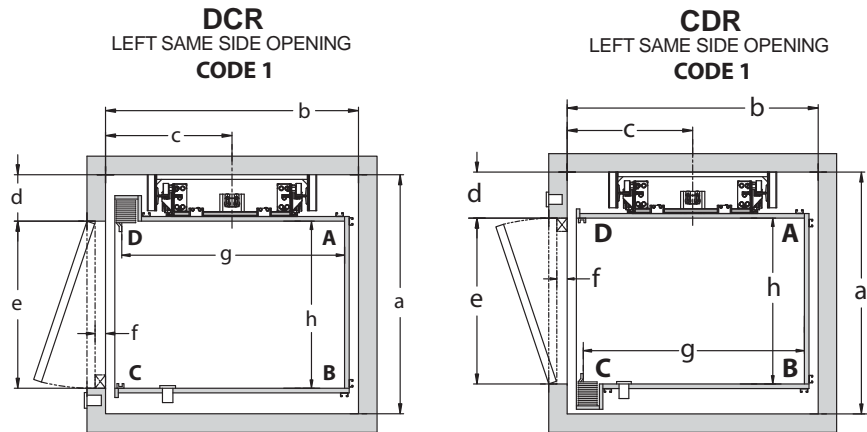

| ELEVATOR HOISTWAY LAYOUT                         |     | SERIES 021 & 022 ELEVATOR HOISTWAY DIMENSIONS |                              |        |       |     |     |    |     |     |
|--|-----|---|------------------------------|--------|-------|-----|-----|----|-----|-----|
|  |     | CAR SIZE                                      | FINISHED HOISTWAY DIMENSIONS |        |       |     |     |    |     |     |
|  |     |   | a                            | b      | c     | d   | e   | f  | g   | h   |
| <b>CODE 1</b><br>LEFT<br>SAME<br>SIDE<br>OPENING | DCR | 48" x 36"                                     | 51.5"                        | 53.75" | 26.5" | 10" | 36" | 3" | 48" | 36" |
|  | DCR | 54" x 40"                                     | 55.5"                        | 59.75" | 29.5" | 14" | 36" | 3" | 54" | 40" |
|  | DCR | 60" x 36"                                     | 51.5"                        | 65.75" | 32.5" | 10" | 36" | 3" | 60" | 36" |
| <b>CODE 1</b><br>LEFT<br>SAME<br>SIDE<br>OPENING | CDR | 48" x 36"                                     | 52.5"                        | 53.75" | 26.5" | 10" | 36" | 3" | 48" | 36" |
|  | CDR | 54" x 40"                                     | 55"                          | 59.75" | 29.5" | 10" | 36" | 3" | 54" | 40" |
|  | CDR | 60" x 36"                                     | 52.5"                        | 65.75" | 32.5" | 10" | 36" | 3" | 60" | 36" |

# Hoistway Layouts - Series 021 & 022

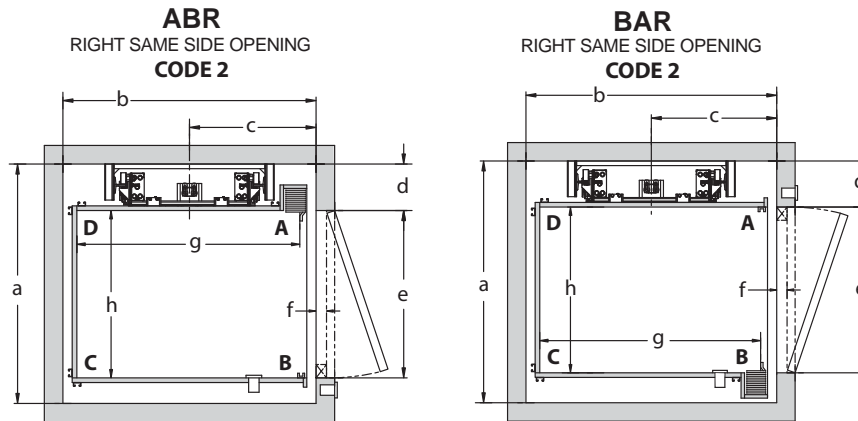

| ELEVATOR HOISTWAY LAYOUT                 |     | SERIES 021 & 022 ELEVATOR HOISTWAY DIMENSIONS |                              |        |       |     |     |    |     |     |
|--|-----|---|------------------------------|--------|-------|-----|-----|----|-----|-----|
|  |     | CAR SIZE                                      | FINISHED HOISTWAY DIMENSIONS |        |       |     |     |    |     |     |
|  |     |   | a                            | b      | c     | d   | e   | f  | g   | h   |
| <b>CODE 2</b><br>RIGHT SAME SIDE OPENING | ABR | 48" x 36"                                     | 51.5"                        | 53.75" | 26.5" | 10" | 36" | 3" | 48" | 36" |
|  | ABR | 54" x 40"                                     | 55.5"                        | 59.75" | 29.5" | 14" | 36" | 3" | 54" | 40" |
|  | ABR | 60" x 36"                                     | 51.5"                        | 65.75" | 32.5" | 10" | 36" | 3" | 60" | 36" |
| <b>CODE 2</b><br>RIGHT SAME SIDE OPENING | BAR | 48" x 36"                                     | 52.5"                        | 53.75" | 26.5" | 10" | 36" | 3" | 48" | 36" |
|  | BAR | 54" x 40"                                     | 55"                          | 59.75" | 29.5" | 10" | 36" | 3" | 54" | 40" |
|  | BAR | 60" x 36"                                     | 52.5"                        | 65.75" | 32.5" | 10" | 36" | 3" | 60" | 36" |

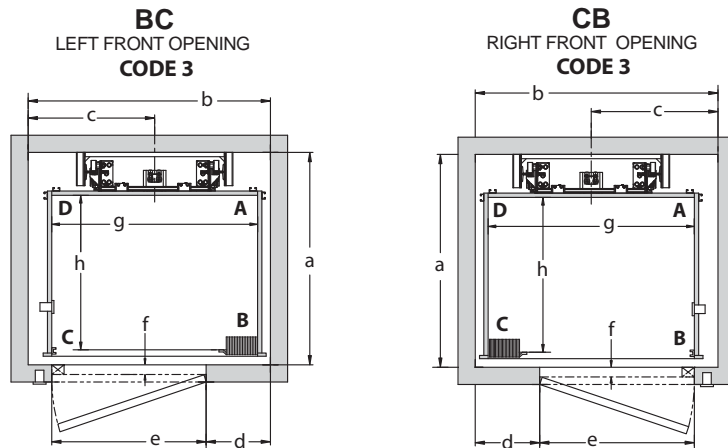

| ELEVATOR HOISTWAY LAYOUT             |    | SERIES 021 & 022 ELEVATOR HOISTWAY DIMENSIONS |                              |       |       |     |     |    |     |     |
|--------------------------------------|----|---|------------------------------|-------|-------|-----|-----|----|-----|-----|
|                                      |    | CAR SIZE                                      | FINISHED HOISTWAY DIMENSIONS |       |       |     |     |    |     |     |
|                                      |    |   | a                            | b     | c     | d   | e   | f  | g   | h   |
| <b>CODE 3</b><br>LEFT FRONT OPENING  | BC | 48" x 36"                                     | 48.75"                       | 56.5" | 29.5" | 15" | 36" | 3" | 48" | 36" |
|                                      | BC | 54" x 40"                                     | 52.75"                       | 62.5" | 32.5" | 21" | 36" | 3" | 54" | 40" |
|                                      | BC | 60" x 36"                                     | 48.75"                       | 68.5" | 35.5" | 27" | 36" | 3" | 60" | 36" |
| <b>CODE 3</b><br>RIGHT FRONT OPENING | CB | 48" x 36"                                     | 48.75"                       | 56.5" | 29.5" | 15" | 36" | 3" | 48" | 36" |
|                                      | CB | 54" x 40"                                     | 52.75"                       | 62.5" | 32.5" | 21" | 36" | 3" | 54" | 40" |
|                                      | CB | 60" x 36"                                     | 48.75"                       | 68.5" | 35.5" | 27" | 36" | 3" | 60" | 36" |



# Hoistway Layouts - Series 021 & 022

**ABR - DCR**  
OPPOSITE OPENING  
**CODE 4**

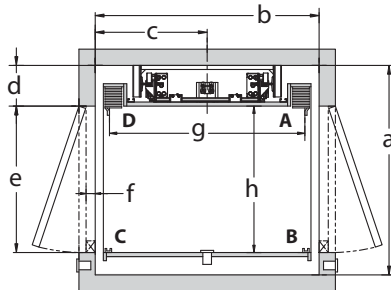

**BAR - CDR**  
OPPOSITE OPENING  
**CODE 4**

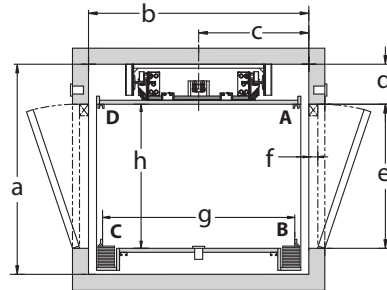

| ELEVATOR HOISTWAY LAYOUT |         | SERIES 021 & 022 ELEVATOR HOISTWAY DIMENSIONS |                              |       |        |     |     |    |     |     |
|--------------------------|---------|---|------------------------------|-------|--------|-----|-----|----|-----|-----|
|                          |         | CAR SIZE                                      | FINISHED HOISTWAY DIMENSIONS |       |        |     |     |    |     |     |
|                          |         |   | a                            | b     | c      | d   | e   | f  | g   | h   |
| <b>CODE 4</b>            | ABR-DCR | 48" x 36"                                     | 51.5"                        | 53.5" | 26.75" | 10" | 36" | 3" | 48" | 36" |
| OPPOSITE OPENING         | ABR-DCR | 54" x 40"                                     | 55.5"                        | 59.5" | 29.75" | 14" | 36" | 3" | 54" | 40" |
|                          | ABR-DCR | 60" x 36"                                     | 51.5"                        | 65.5" | 32.75" | 10" | 36" | 3" | 60" | 36" |
| <b>CODE 4</b>            | BAR-CDR | 48" x 36"                                     | 52.5"                        | 53.5" | 26.75" | 10" | 36" | 3" | 48" | 36" |
| OPPOSITE OPENING         | BAR-CDR | 54" x 40"                                     | 55"                          | 59.5" | 29.75" | 10" | 36" | 3" | 54" | 40" |
|                          | BAR-CDR | 60" x 36"                                     | 52.5"                        | 65.5" | 32.75" | 10" | 36" | 3" | 60" | 36" |

**ABR - BC**  
RIGHT ADJACENT 90° OPENINGS  
**CODE 5**

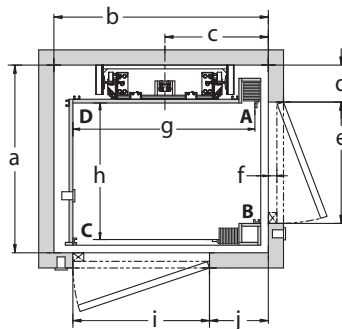

**DCR - CB**  
LEFT ADJACENT 90° OPENINGS  
**CODE 6**

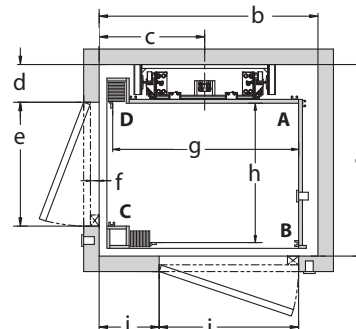

| ELEVATOR HOISTWAY LAYOUT                    |        | SERIES 021 & 022 ELEVATOR HOISTWAY DIMENSIONS |                              |        |       |       |     |    |     |     |     |        |
|---|--------|---|------------------------------|--------|-------|-------|-----|----|-----|-----|-----|--------|
|   |        | CAR SIZE                                      | FINISHED HOISTWAY DIMENSIONS |        |       |       |     |    |     |     |     |        |
|   |        |   | a                            | b      | c     | d     | e   | f  | g   | h   | i   | j      |
| <b>CODE 5</b><br>RIGHT ADJACENT 90° OPENING | ABR-BC | 48" x 36"                                     | 48.75"                       | 56.25" | 26.5" | 9.75" | 32" | 3" | 48" | 36" | 36" | 14.75" |
|   | ABR-BC | 54" x 40"                                     | 52.75"                       | 61.75" | 29.5" | 9.75" | 36" | 3" | 54" | 40" | 36" | 20.75" |
|   | ABR-BC | 60" x 36"                                     | 48.75"                       | 67.75" | 32.5" | 9.75" | 32" | 3" | 60" | 36" | 36" | 26.75" |
| <b>CODE 6</b><br>LEFT ADJACENT 90° OPENING  | DCR-CB | 48" x 36"                                     | 48.75"                       | 56.25" | 26.5" | 9.75" | 32" | 3" | 48" | 36" | 36" | 14.75" |
|   | DCR-CB | 54" x 40"                                     | 52.75"                       | 61.75" | 29.5" | 9.75" | 36" | 3" | 54" | 40" | 36" | 20.75" |
|   | DCR-CB | 60" x 36"                                     | 48.75"                       | 67.75" | 32.5" | 9.75" | 32" | 3" | 60" | 36" | 36" | 26.75" |

# Hoistway Illustrations - Series 021 & 022

Typical layouts shown here may vary from your actual hoistway. The purpose of these layouts are for a general understanding. Please refer to the Waupaca Elevator drawings and specifications that will be provided by your local dealer.

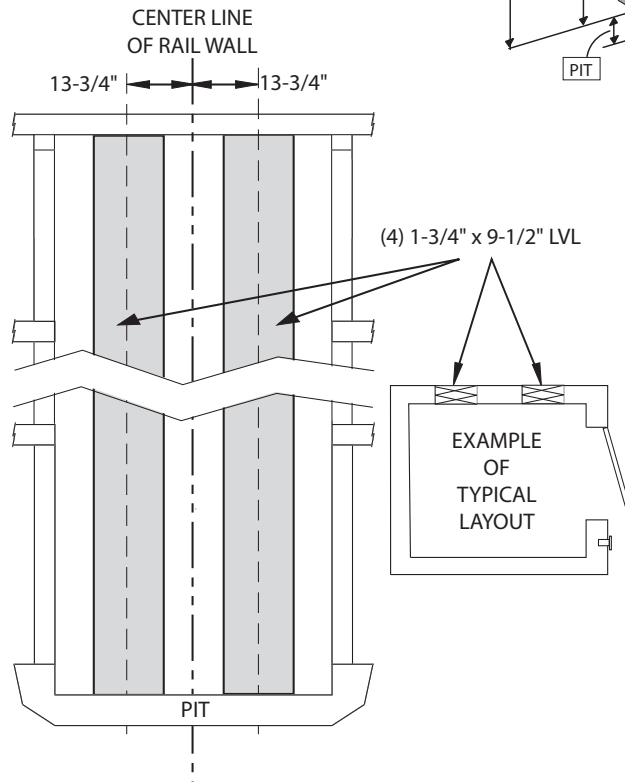
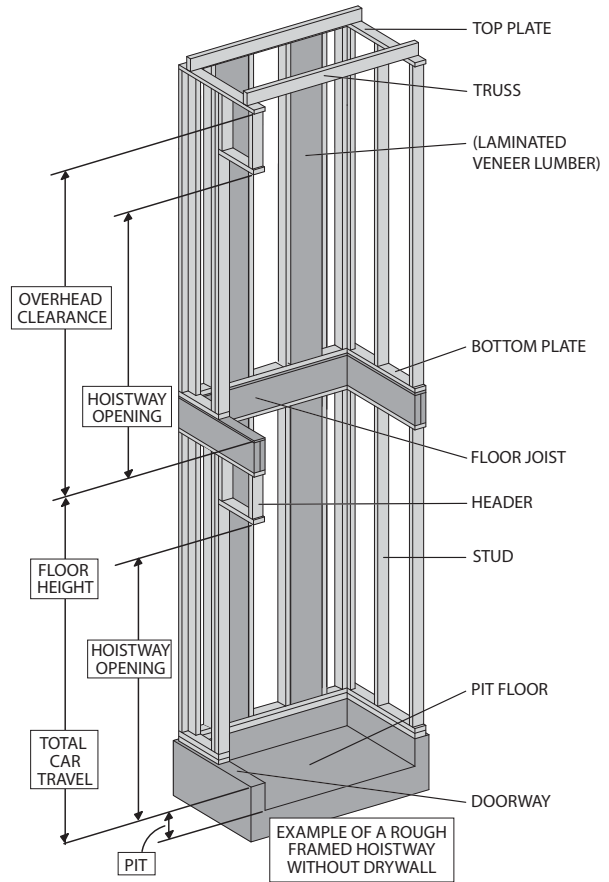

**These drawings depict sample construction only. It is the responsibility of the installer/contractor or engineer to design and specify structural supports. All construction to be in compliance with local codes.**

# Hoistway Specifications - Series 021 & 022

## ATTENTION CONSTRUCTION CONTRACTOR:

This is an example of a hoistway. Job specific documentation will be provided by Waupaca Elevator from which to construct the hoistway.

**Hoistway Construction Requirements** to be completed prior to elevator installation by contractor

1. **Electrical Requirements By Others:**

- Dedicated 230 Volts, 30 AMP Single Phase, 60 Hertz.
- A fused disconnect switch with branch 3 pole circuit wire to suit a 35 AMP service, fused for 30 AMP dual element (time delay fuse).
- 115 Volt, 15 AMP single phase circuit for car lighting.
- Electrical wiring to comply with applicable codes.
- Any VAC other than 230 VAC may require a buck/boost transformer.

**NOTE :**

Electrical requirements are for general reference only. All job specific electrical requirements must be acquired from job specific drawings provided by Waupaca Elevator Company, Inc.

2. **Unfinished/Un-installed Door** - Installation company may prefer a minimum of one hoistway door and associated framing be left unfinished/un-installed to accommodate elevator installation equipment and to prevent accidental damage to door and framing (preferably at grade level).
3. **Plumb and Square Hoistway** - Hoistway must be plumb within 1/8 inch per 10 ft. of height and square at any point within 1/4 inch based on difference in diagonal measurements.
4. **Supportive Structure** - Structure must be capable of supporting the appropriate loads. Local engineering support is recommended.
5. **Telephone Connection** - Code requires a telephone connection to the elevator car; therefore, a phone line must be installed leading to the controller.
6. **ASME 17.1 Section 5.3** - Hoistway to be constructed in accordance with ASME 17.1 Section 5.3 and all local codes.
7. **Hoistway Door Security (Interlocks)** - All hoistway doors require interlocks as well as a door handle and a latch set. Interlocks will be installed by the elevator installers. Waupaca Elevator recommends the use of solid core doors.
8. **Hoistway Requirements** - Any operating equipment must meet N.E.C. code and all local codes. Machine space (if applicable) must have a light switch and a convenience outlet. Temperature must be maintainable between 60-110 ° F and must not be exposed to the elements (with a relative humidity not to exceed 95%).
- NOTE:**  
The frequency drive may be heard running for thermal heat dissipation at any time.
9. **No Alterations** - Any alterations to the equipment without written authorization by Waupaca Elevator will void all warranties.
10. **Pit Floor Strength** - Load on pit floor is 4, 750 lbs. (minimum pit depth of 8”).
11. **Rated Load** - Elevator system is rated for maximum capacity from the factory. Flooring, walls, trim, base, and/or permanent decor added to elevator car must be subtracted from car capacity.

# Hoistway Elevation View and Rail Layout - Series 021

## Required Overhead Heights

|                                  |        |       |       |        |
|----------------------------------|--------|-------|-------|--------|
| Inside Cab Dimension             | 6' 10" | 7' 0" | 7' 4" | 8' 0"  |
| Minimum Hoistway Overhead Height | 9' 0"  | 9' 2" | 9' 6" | 10' 2" |

\* Custom sized cabs will alter these dimensions. Waupaca Elevator will provide you with the appropriate dimensions. Please contact your local dealer to acquire alternate layouts.

Structure is required to support lifting device for powerhead installation. Locate near center of shaft (by others) minimum rating for 1,000 lbs. Additional space may be required for hoisting and maneuvering equipment into place.

This is a graphical representation of Waupaca Elevator's Excelelevator Series which offers a total of six stops and a total travel distance of 50 feet.

## Elevation

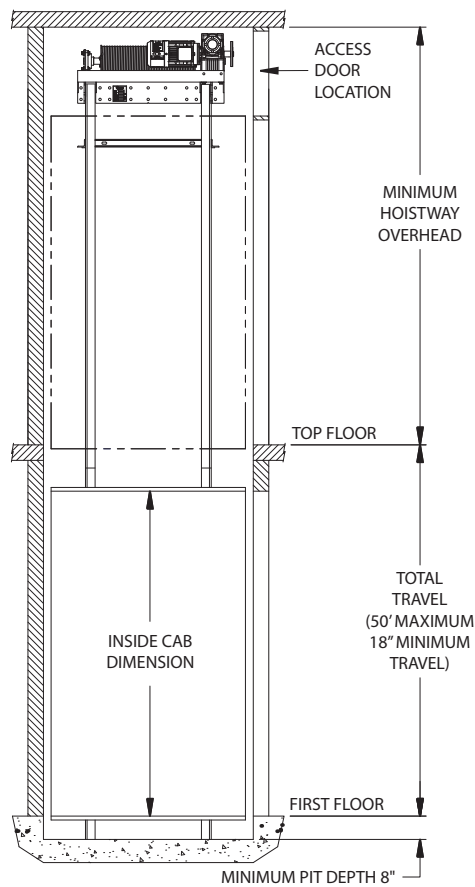

Note:  
Controller to be located outside of hoistway.

## Rail Layout

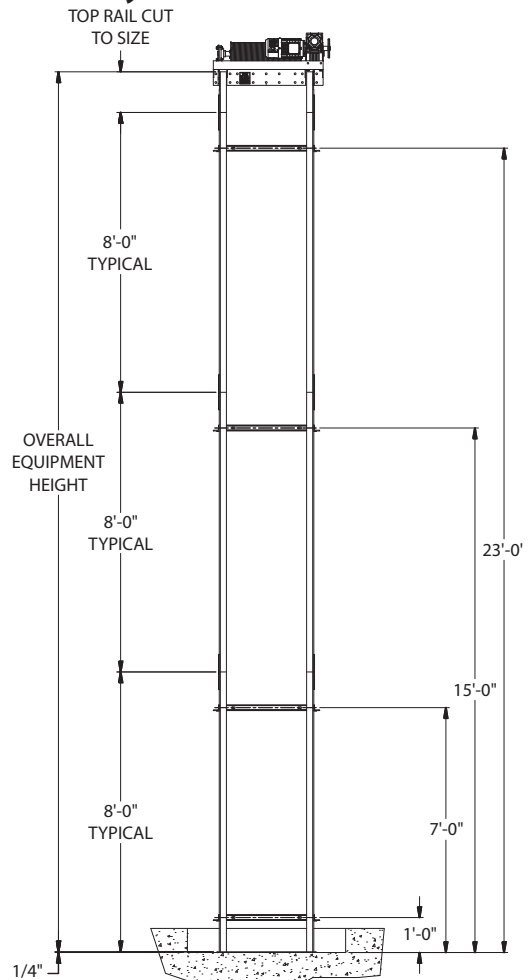

## Rail Calculations

Rail Length =  
Pit Depth + Travel + Car I.D. Height + 12"

# Hoistway Elevation View and Rail Layout - Series 022

## Required Overhead Heights

|                                  |       |      |      |      |
|----------------------------------|-------|------|------|------|
| Inside Cab Dimension             | 6'10" | 7'0" | 7'4" | 8'0" |
| Minimum Hoistway Overhead Height | 7'10" | 8'0" | 8'4" | 9'0" |

\* Custom sized cabs will alter these dimensions. Waupaca Elevator will provide you with the appropriate dimensions. Please contact your local dealer to acquire alternate layouts.

This is a graphical representation of Waupaca Elevator's Excelelevator Series which offers a total of six stops and a total travel distance of 50 feet.

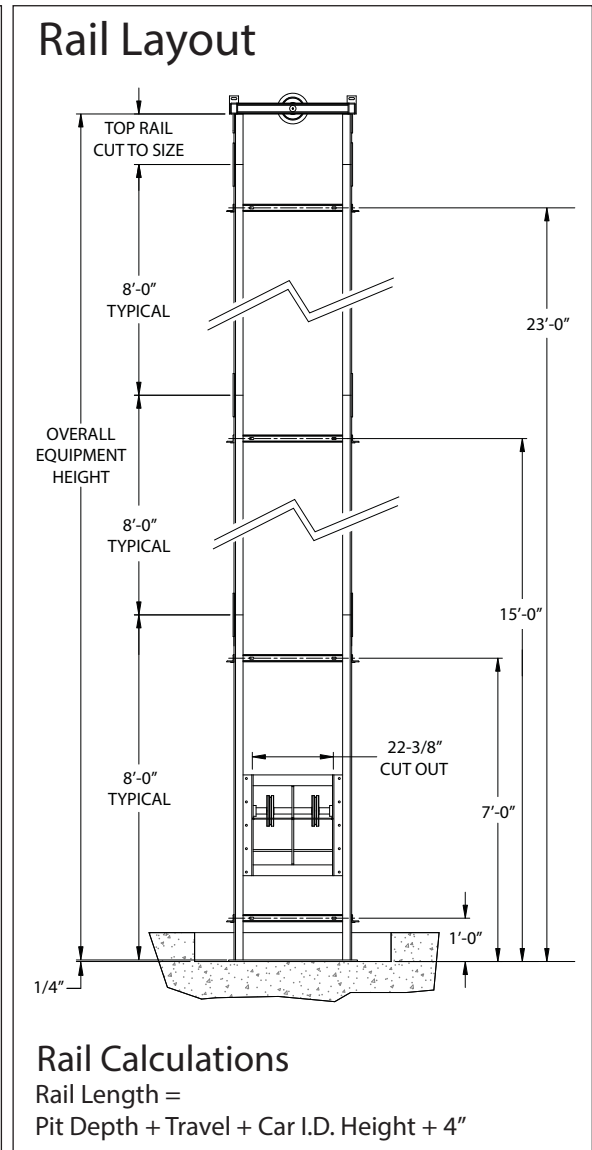
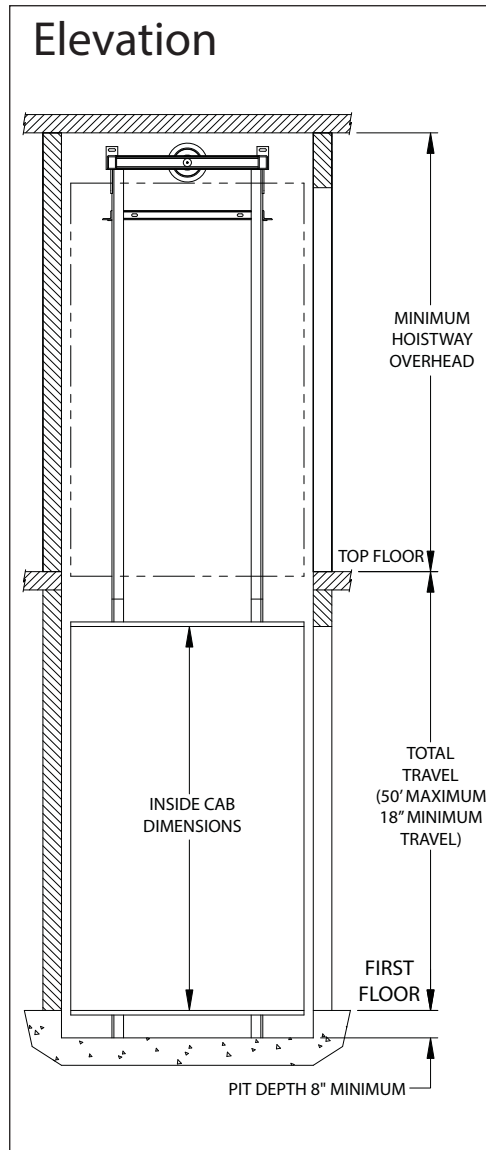

# Machine Room & Controller Location

## Typical 1<sup>ST</sup> Floor Machine Room Layout Series 022 Shown

1. The controller requires minimum clear space of 36" x 30" located directly in front of the controller (refer to illustration).
2. A lockable service disconnect must be placed within sight of the controller and must be easily accessible from the latch side of the doorway (if applicable).
3. A machine room or enclosure must be provided that meets national electrical code clear space requirements and all local codes. The machine room must contain a convenience outlet and light with switch. Temperatures in the machine room must be maintained between 60° - 110°F and must not be exposed to the elements (with a relative humidity not to exceed 95%).

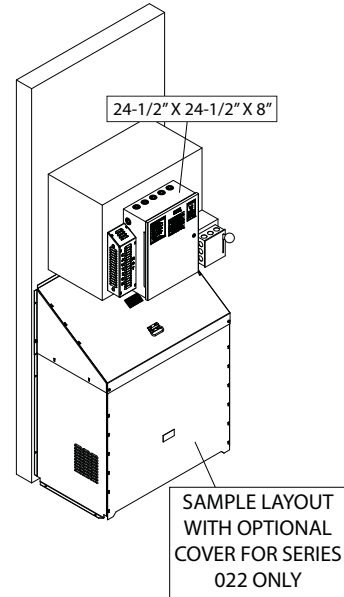
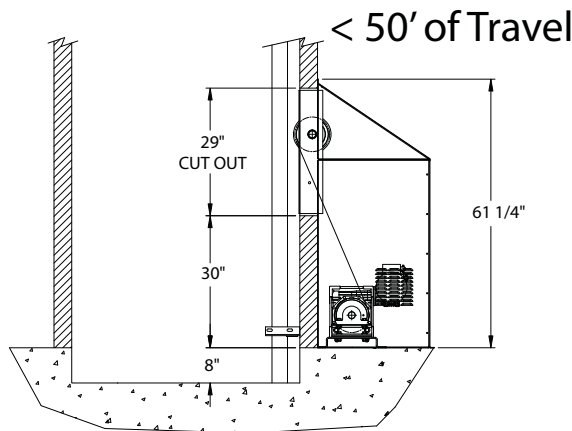
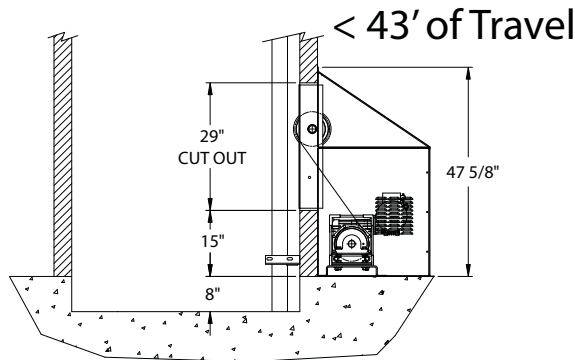
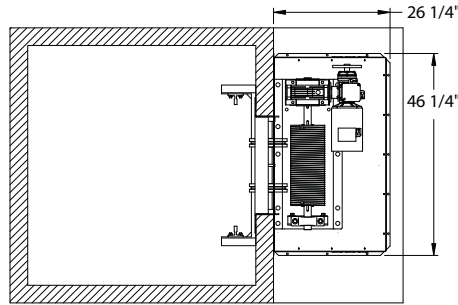

**NOTE:**

The frequency drive may be heard running for thermal heat dissipation at any time.

Note: Layouts on this page apply to first floor machine room location only. Layouts may change depending on which floor contains the machine equipment. Contact Waupaca Elevator, Co., for more information.

# Elevator Equipment - Series 021 & 022

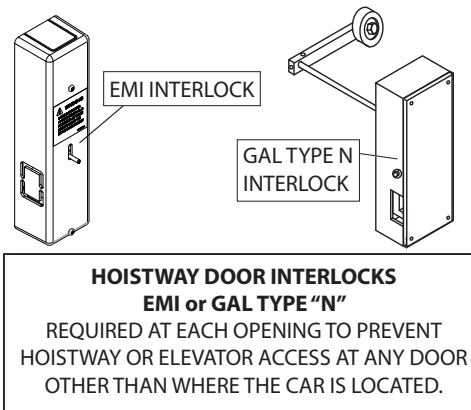
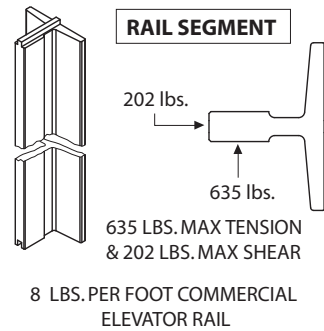
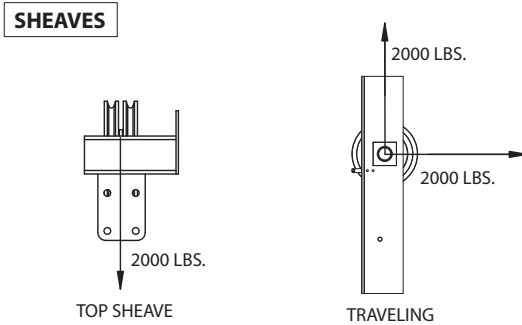
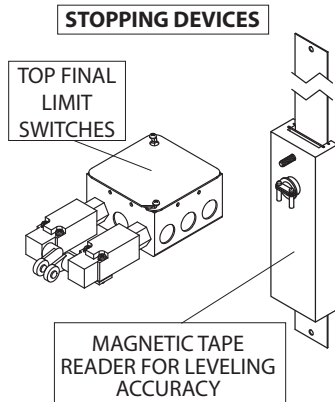
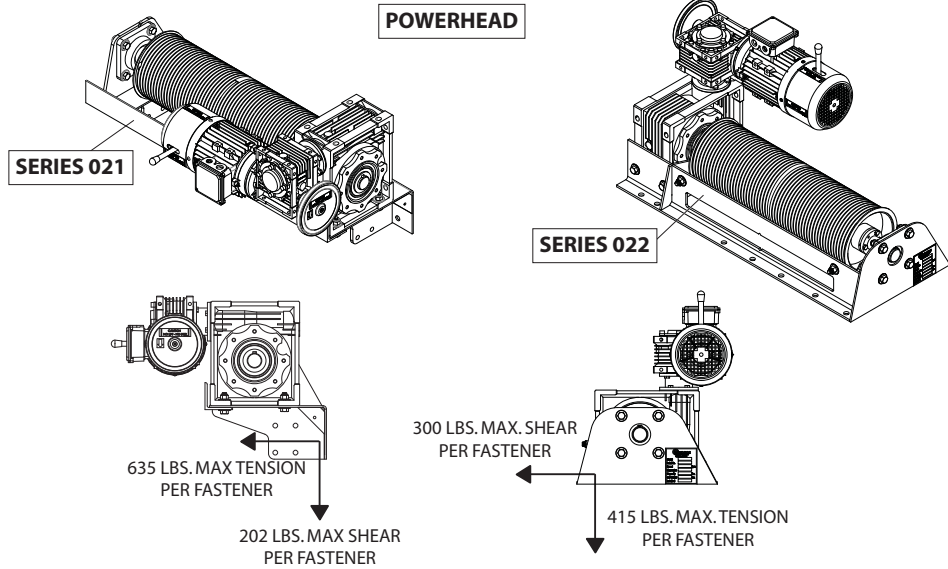

# Series 021 Mechanical Illustrations

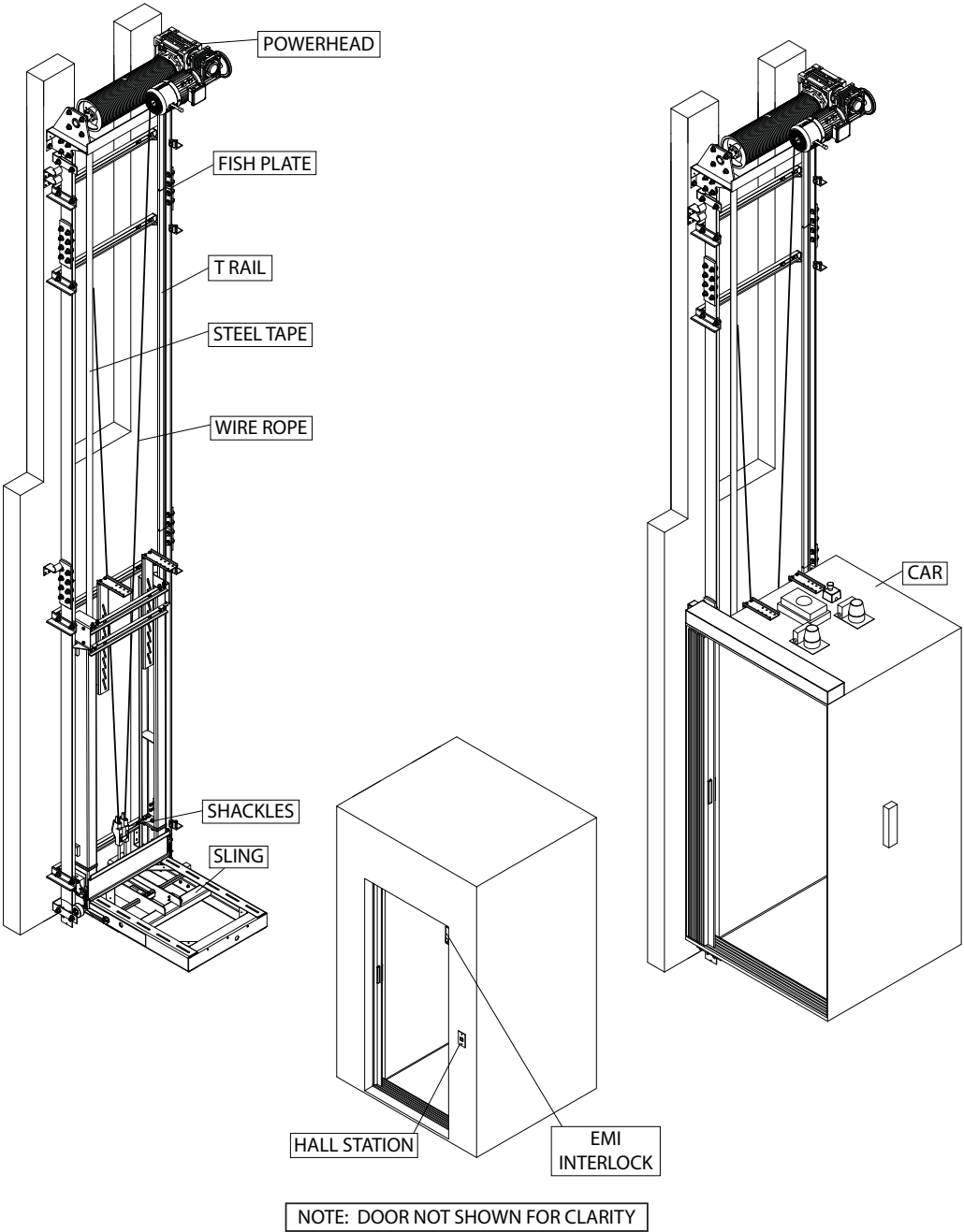



# Series 022 Mechanical Illustrations

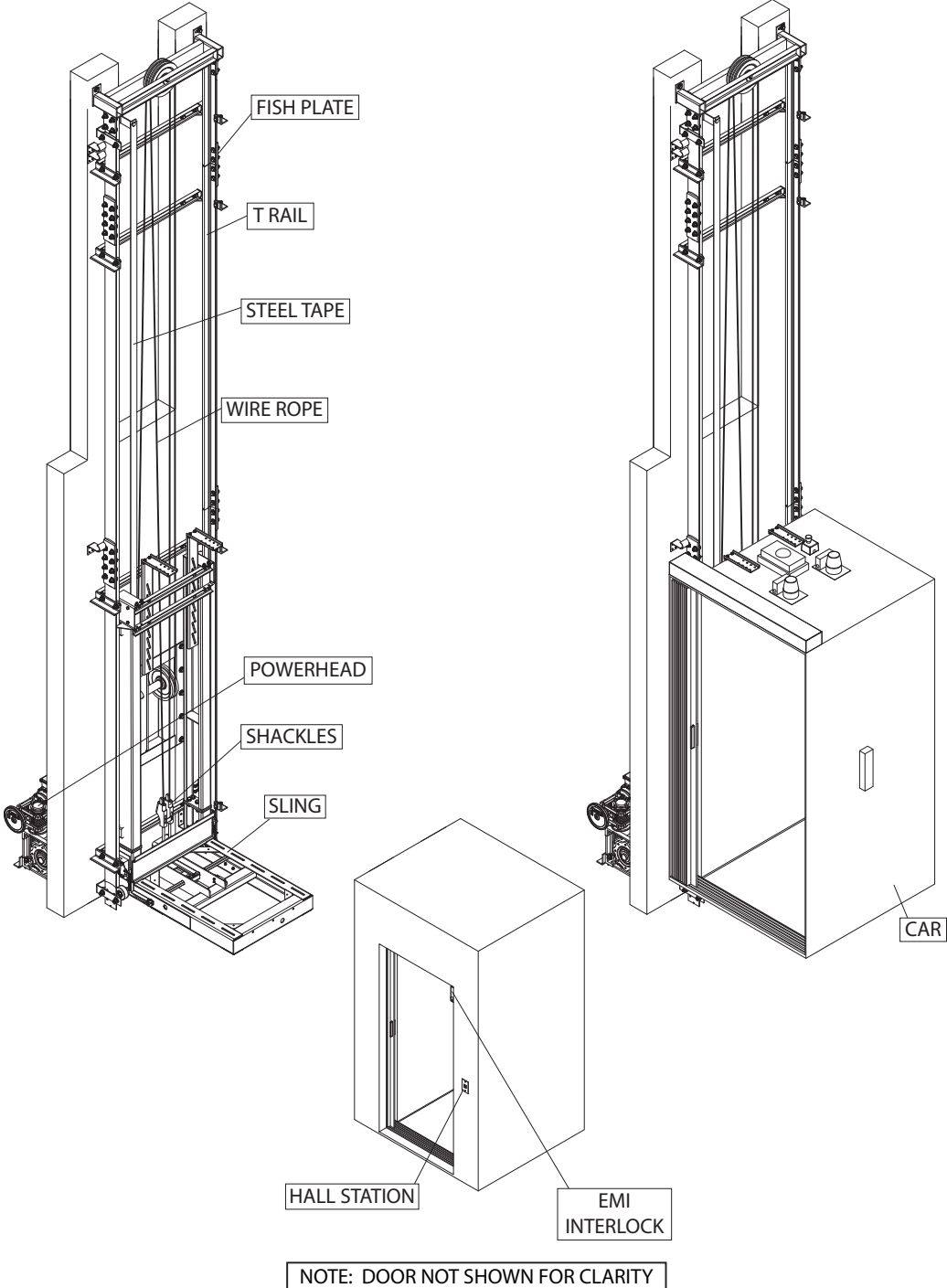

PMQ0700-F  
03-14-2013

1726 North Ballard Road • Appleton, WI 54911  
Phone 920-991-9082 • [www.waupacaelevator.com](http://www.waupacaelevator.com)

