

# INCLINATOR<sup>®</sup> MACHINE ROOM HOME ELEVATORS

*Elevette<sup>®</sup>: America's most customizable brand*



**INCLINATOR**  
COMPANY OF AMERICA



# *An elevator in your home is a matter of convenience.*



A home elevator makes it easier for people and items to move from floor to floor. Whether you're carrying groceries to your upstairs kitchen in a waterfront home or heading to the lower level garage in a mountain resort, not having to walk stairs makes your life easier. It also gives people in wheelchairs – and those using walkers – the ease of accessing every floor of the home.

## **It's also a sound investment.**

The increase in your home's value often exceeds the cost of an elevator. It also makes your home ideal for resale to the growing market of older buyers.

## **It fits in any multi-floor home.**

It uses a quarter of the space of a staircase. It can be designed into new construction or added during renovation. It can be housed in a shaft or in an open environment.



# *Not only did we invent the home elevator, but we continue to perfect it.*

There are more Inclinator elevators in homes across the country than any other brand. Architects love them because of the near endless design possibilities. Homeowners love them for their beauty and reliability. Whatever the reasons, Inclinator's Elevette® is the number one choice of home elevators.

## **Reliable products. Exceptional service.**

In addition to having the most choices and custom features in the industry, Inclinator is known for building reliable products and maintaining a solid network of certified installers and service contractors. Inclinator is the best name in the industry because it builds the best home elevator and backs it with valuable technical support and exceptional customer service.

Inclinator offers a three-year warranty on its hydraulic drive system and a two-year warranty on its cable drum drive system that guarantees that the elevator and its parts will be free of defects in workmanship and material.

*See our Machine Roomless Elevators brochure for more drive system options.*



Car interior shown with custom light and finish.

**Inclinator Company of America** goes back to 1923, when Harrisburg, PA, inventor C.C. Crispen created a way to enable his ailing friend to travel from floor to floor. His idea was to build a seat that would climb stairs. He called it the Inclinator. Five years later, he built his first Elevette elevator as an alternative for homes with winding staircases.

Along the way, vertical wheelchair lifts and dumbwaiters were added. Inclinator remains a family-owned business located in Harrisburg, PA. Every Inclinator product is manufactured and assembled in its South Central Pennsylvania plant.

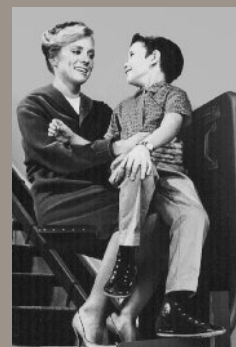

*Inclinator stair chair*

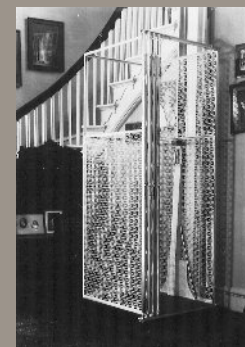

*Elevette home elevator*



# Car Styles

## “Custom” is a standard at Inclinator.

Inclinator handcrafts each elevator, allowing you to select from more car widths, depths and heights than any other elevator manufacturer up to 15 sq. ft. as allowed by code. Inclinator elevators can have up to three door openings in any configuration. Other custom features include woods and finishes, handrails, lighting, gates and control plates.

Inclinator’s custom capabilities allow for adding elevators to existing homes.

## No other manufacturer offers more custom features for machine room elevators.

- Custom sizes up to 15 sq. ft.
- Door openings on 1, 2 or 3 sides
- Nearly all wood species available
- Stained or painted in factory or on site
- Commercial-grade laminate flooring with simulated wood grain finish
- Unfinished oak veneer flooring available to accommodate on-site flooring
- In-shaft or no shaft (consult local codes)
- Cable Drum & Hydraulic Drives
- 500 lb. and 950 lb. capacity
- Automatic safety devices



## ELEVETTE® 500

Powder-coated extruded aluminum frame with acrylic panels

*Available with Hydraulic and Cable Drum drives for in-shaft applications, and Cable Drum drive for no-shaft applications.*



## IN-SHAFT

Most Inclinator elevators operate within an enclosed shaft. Occasionally, shafts are designed into projects and saved for future elevator installation. Prior to use as an elevator shaft, it can be used as closets stacked on top of each other.



## NO SHAFT

Inclinator’s Cable Drum elevator can be installed in an “open” environment – running up the center of open winding stairs, next to stairways and where no stairs exist.

Consult local codes for allowable applications.



**ELEVETTE® 400**

Solid wood with hardwood veneer raised or recessed center panels

*Panel Configurations: 2-over-2 or 1-over-1*



**ELEVETTE® 300**

Smooth hardwood center panels with crown, chair, baseboard and picture molding



**ELEVETTE® 200**

Smooth hardwood veneer panels with square, flush corners

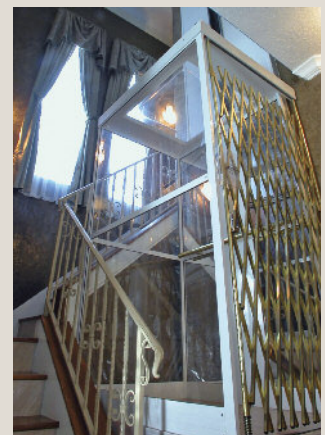



# Car Finishes & Accessories

## Walls

Just about any wood species available can be used for construction. The majority of cars are made using hardwoods and veneers in one of the standard or premium woods shown. Available in semi-gloss coat or satin finish. Most cars are finished in the factory, but they can remain unfinished for on-site, custom finishing.

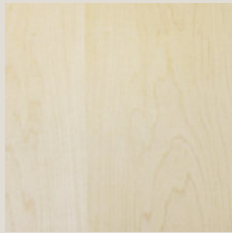

Maple (standard)

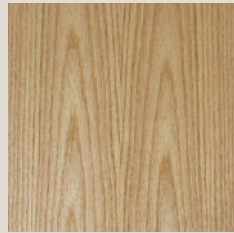

Red Oak (standard)

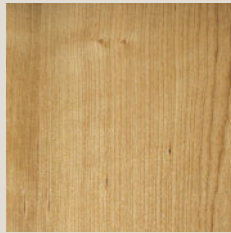

Cherry (standard)

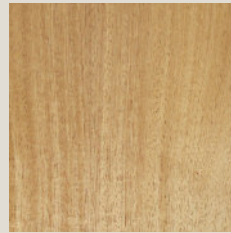

Mahogany (standard)

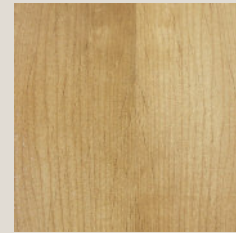

Clear Alder (premium)

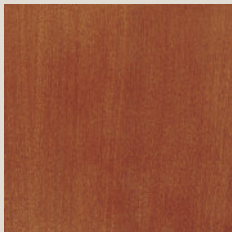

Stained Cherry (premium)

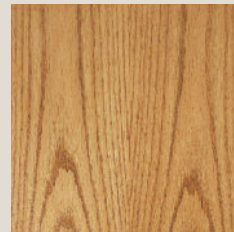

Medium Oak (premium)

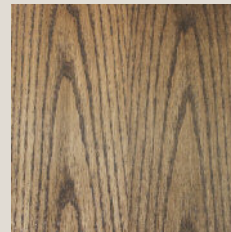

Dark Oak (premium)

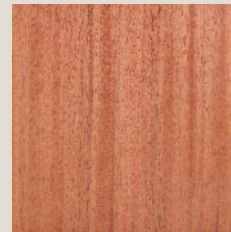

Stained Mahogany (premium)

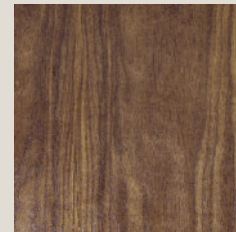

Walnut (premium)

## Floor

Inclinators include hardwood laminate finishes for floor. Elevators can also be ordered with custom flooring or with unfinished oak for custom on-site finishing.



Maple (laminate)

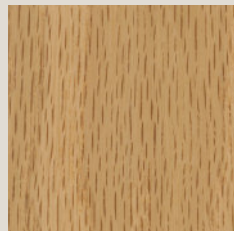

Natural Oak (laminate)

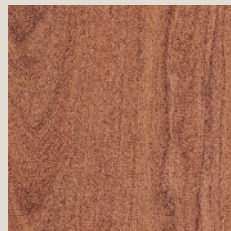

Cherry (laminate)

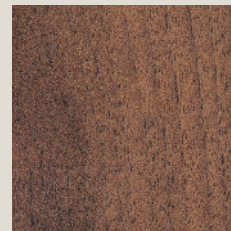

Walnut (laminate)

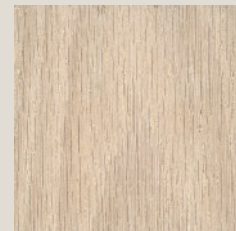

Unfinished Oak

## Ceiling

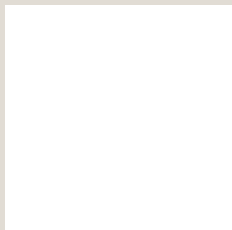

White (laminate)

Elevator ceiling can be white laminate or any of the "standard" wall veneers above. "Premium" hardwoods are available as an option.

Actual colors may vary slightly from printed samples.



## Handrails

One flat wood handrail (finished to match walls) comes standard. Optional round metal handrails are available in various finishes. Custom designs and finishes are always available.



Standard wood handrail matches wall finish.

### Optional:



## Lights & Trims

1-light or 2-light standard. Additional lights and different fixtures are optional.

### STANDARD: 6" Down Light with Glass Lens



Polished Stainless Steel Ring

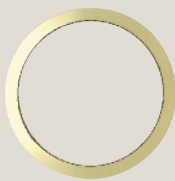

Brass Ring



Bronze Ring



Oil-Rubbed Bronze Ring



Duranotic Ring



White Ring

### OPTIONAL: Down Lights Flush with Dome



Surface Mounted Light  
2" x 9-1/2" x 9-1/2"



6" Down Light  
with black cone baffle  
& white trim ring



4" Down Light  
with white cone baffle

Actual colors may vary slightly from printed samples.

# Car Finishes & Accessories



## Gates

Inclinators elevators come with collapsible gate. Accordion fold gate available. Automatic gate operator available (accordion fold gate required).

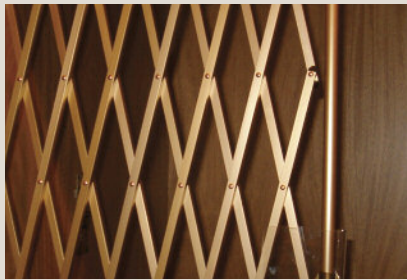

Collapsible Gate

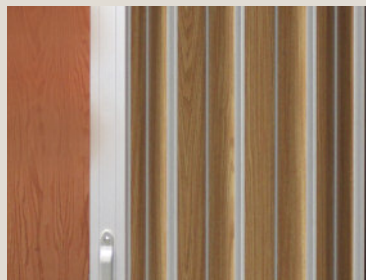

Accordion Fold Gate



Extruded gate track matches metal finish on either gate option.

## Standard Metal Finishes



Silver

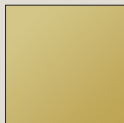

Brass

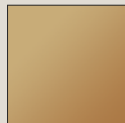

Bronze

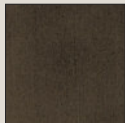

Oil-Rubbed Bronze

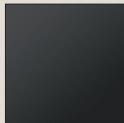

Duranotic

## Hardwood Finishes



Maple/Birch

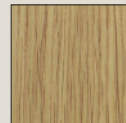

Oak

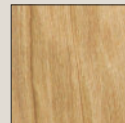

Cherry

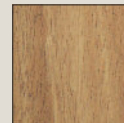

Mahogany

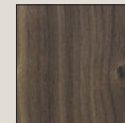

Walnut

## Vinyl Laminates



Maple/Birch

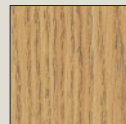

Light Oak

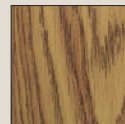

Dark Oak

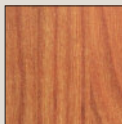

Cherry

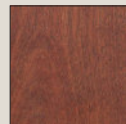

Mahogany

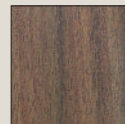

Walnut

## Acrylic Vision Panels

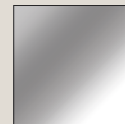

Clear

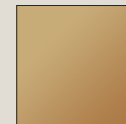

Bronze (tint)



## Gate Safety Switch

This requires the gate to remain closed during the car's movement.



## Car Floating Gate Switch

This stops the car when an object extends through the gate and forces it up or down.



White

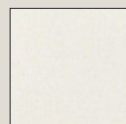

Antique White



Chalk



Beige

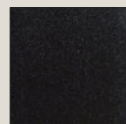

Black

## Accordion Fold Gate Frames



Nickel



Brass (premium)



Bronze



White (premium)

Actual colors may vary slightly from printed samples.



# Drive Systems

## Cable Drum Drive

- Cable drum: quietest in the industry
- Patented, space-saving monorail guiding system
- 500 lb. & 950 lb. capacity
- Can accommodate car size up to 15 sq. ft.
- Flexible machine room location
- Emergency battery lowering
- Standard 2-year warranty

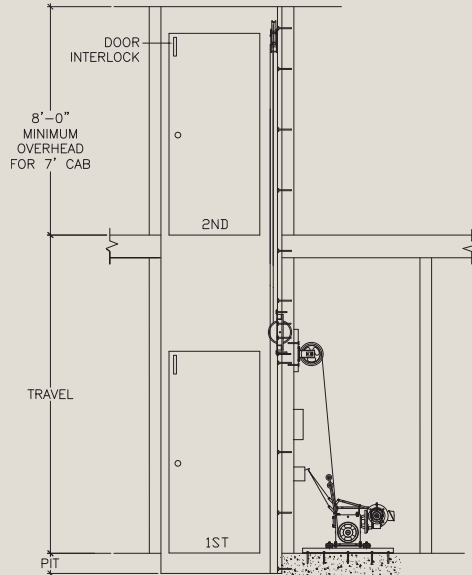

6" MINIMUM PIT FOR 500# UNIT  
10" MINIMUM PIT FOR 950# UNIT

## Hydraulic Drive

- Hydraulic: smooth, quiet ride
- Patented, space-saving monorail guiding system
- 950 lb. capacity
- Can accommodate car size up to 15 sq. ft.
- Flexible machine room location
- Pre-wire package available
- Emergency battery lowering
- Standard 3-year warranty

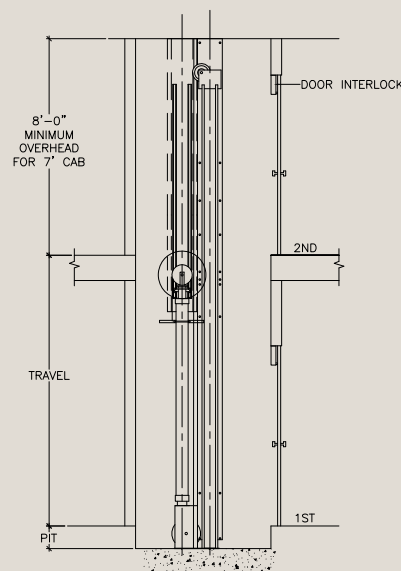

10" MINIMUM PIT FOR 950# UNIT



# Car Operating Stations

## Car Operating Panel

Car Operating Panel comes in a variety of finishes. Plate configuration is determined by the elevator's features and options.



Standard

Arc

Bell

Car Operating Panel – choose the original rectangular plate shape, or one of two decorative plate shapes – available at no up-charge.

## Remote Call Station

Remote Call Station comes in a variety of finishes. Plate configuration is determined by the elevator's features and options.



Standard Remote Call Station (at each landing).

Remote Call Station (at each landing) shown with optional in-use light and key switch.

## Standard Finishes

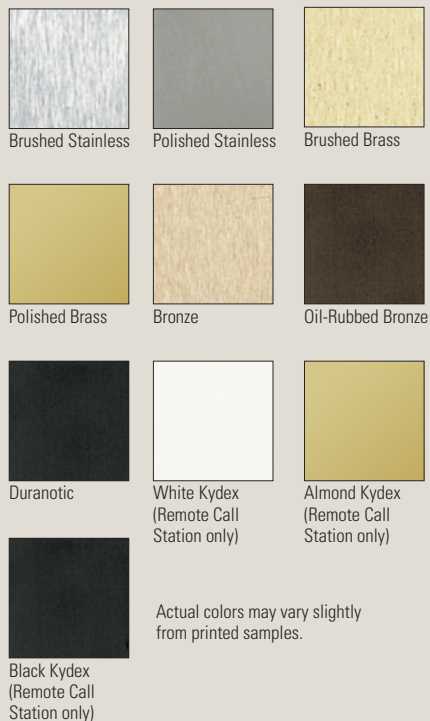

Actual colors may vary slightly from printed samples.





# Elevator Details



## Typical Car Configurations

Elevator car can have door openings on 1, 2 or 3 sides. As you can see, Inclinator offers more configurations than any other manufacturer.



Some configurations are not suitable for wheelchair use. Consult Inclinator (manufacturer) for recommendations.

## Shaft Sizes

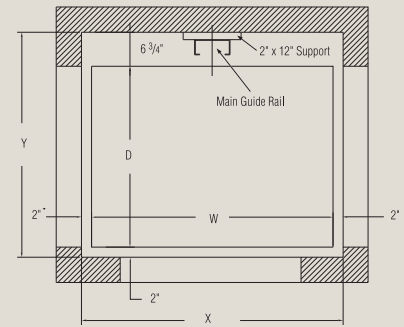

Notes:

- Typical 1" running clearance from finished hoistway to edge of car at all door openings
- 3" running clearance needed for stabilizer or 4" running clearance needed for pre-wire package stabilizer
- Minimum overhead needed for 7' tall car is 8'-0"

## Other Automatic Safety Devices

- Car gate and door safety devices cease elevator operation when opened
- Instantaneous dual cable safeties
- Overrun switch
- Slack cable mainline disconnect switch (Cable Drum Drive)

## No-Shaft Safety Devices

- Safety stop diaphragm and pressure-sensitive interlocked floor door (for 2-landing, cable drum, open-type elevators)
- Double-action gate lock prevents gate opening while car is in motion
- Constant pressure controls



*You can be confident in choosing an Inclinator product*



### HOME ELEVATORS

- The industry's most customizable home elevator
- Two lines: Elevette® machine room and Inclinator® machine roomless



### WHEELCHAIR LIFTS

- Indoor and outdoor use
- Two lines: SpectraLift® (fiberglass) and VL (steel)



### DUMBWAITERS

- Custom sizes and features
- Two lines: Dumbwaiter (commercial use) and Homewaiter® (residential use)

Consult your local building authorities for specific regulations on these products before purchasing. Specifications, material finishes and product options are subject to change without notice.



601 Gibson Boulevard  
 Harrisburg, PA 17104  
 Phone: 717-939-8420  
**Toll-Free: 800-343-9007**  
**www.inclinator.com**  
 isales@inclinator.com

©2011, Inclinator Company of America  
 Printed in USA, All Rights Reserved

29305355 • SPCTM-5M-712