

GENESIS OPAL

DESIGN AND PLANNING GUIDE



Unenclosed Platform Lift for lifting heights up to 5 feet

Please note:

Dimensions provided in this Guide are for **REFERENCE ONLY** and should not be used for site preparation or construction.

Genesis Opal Table of Contents

What is an Unenclosed Vertical Platform Lift?.....	4
Finishes	4
Design Versatility	4
Component Identification.....	5
Platforms	6
Platform Controls	6
Platform Clear Dimensions	7
Platform Safety Features	8
User Friendly Features	8
Footprint and Pit/Runway Dimensions.....	9
Mast Sizes	10
Leadscrew Drive System.....	11
Hydraulic Drive System (USA).....	11
Drive System Features and Options.....	11
Call Stations	12
Gates.....	13
Ramps	15
Lower Landing Ramp Dimensions.....	15

What is an Unenclosed Vertical Platform Lift?

An unenclosed vertical platform lift easily transports passengers up and down short vertical distances, for applications such as stages and porches. The platform walls, platform gate and optional automatic ramp travel with the platform creating a safety barrier around the passenger. Available for indoor and outdoor applications, the **Garaventa Genesis OPAL Lift** is an attractive and cost-effective accessibility solution.

Why an Unenclosed Vertical Lift?

An Unenclosed Vertical Lift vs a Ramp

An unenclosed vertical lift occupies less space than most ramps and is easier to use by those individuals who have difficulty ascending ramps.

Cost Effective with a Quick Delivery

An unenclosed vertical platform lift has lower equipment and installation costs compared to other types of accessibility equipment. In most cases, an unenclosed vertical lift can be delivered within a few weeks.

Commercial or Home Installation

An unenclosed vertical lift requires little or no site modifications and is an ideal accessibility solution when space and costs are the primary concerns. They are commonly used in public buildings and private residences.

Meets Accessibility Requirements

Unenclosed vertical lifts meet the requirements of most local accessibility guidelines as a means to provide unassisted entry and exit from public buildings.

Meets US and European Codes

The Genesis OPAL is built in accordance with ASME A18.1 (USA), BSI (UK) and CE (Europe) code requirements.

Finishes

The Genesis OPAL consists of steel panels and frame work finished with electrostatically applied Satin Grey (fine textured) paint. As an option, these components can be painted from the large selection of RAL colors.

Design Versatility

The Garaventa Genesis OPAL vertical lift is suitable for short rise applications with **straight through** or **90° entry/exit** configurations, and can be used **indoors** or **outdoors**.

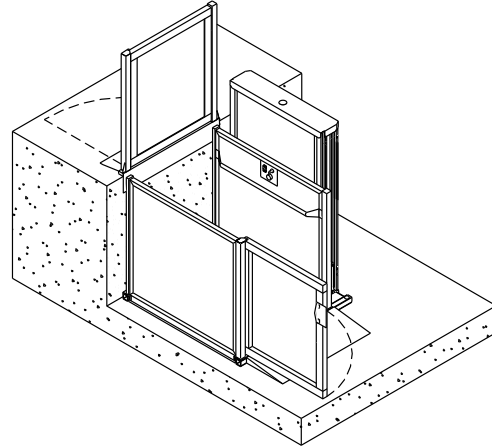

Straight-Through Configuration

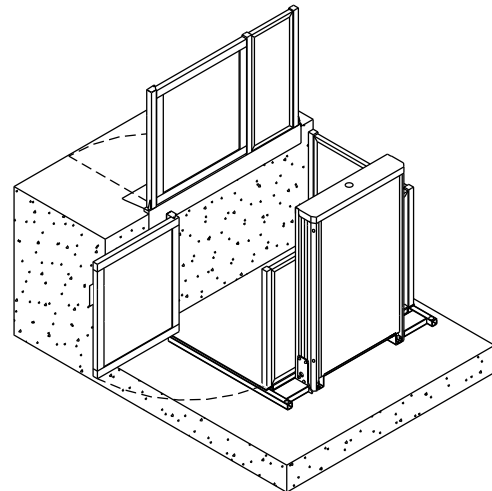

90° Configuration

Applications Include:

- Schools
- Courthouses
- Theaters
- Restaurants
- Hospitals
- Churches
- Commercial Buildings
- Historical Buildings
- Residential
- And Many More

For a list of installations in your area please contact your local Garaventa Lift representative or Garaventa Lift.

Component Identification

The Genesis Vertical Platform Lift is offered in a variety of models to accommodate different accessibility challenges. This Design and Planning Guide applies to the unenclosed vertical lift which is called the Genesis OPAL Model.

The Genesis OPAL consists of a complete vertical elevating system placed on the floor or in a 76mm (3") deep pit. It is constructed of a champagne colored, anodized aluminum extrusions and powder coated steel, a steel platform and 16 gauge powder coated panels.

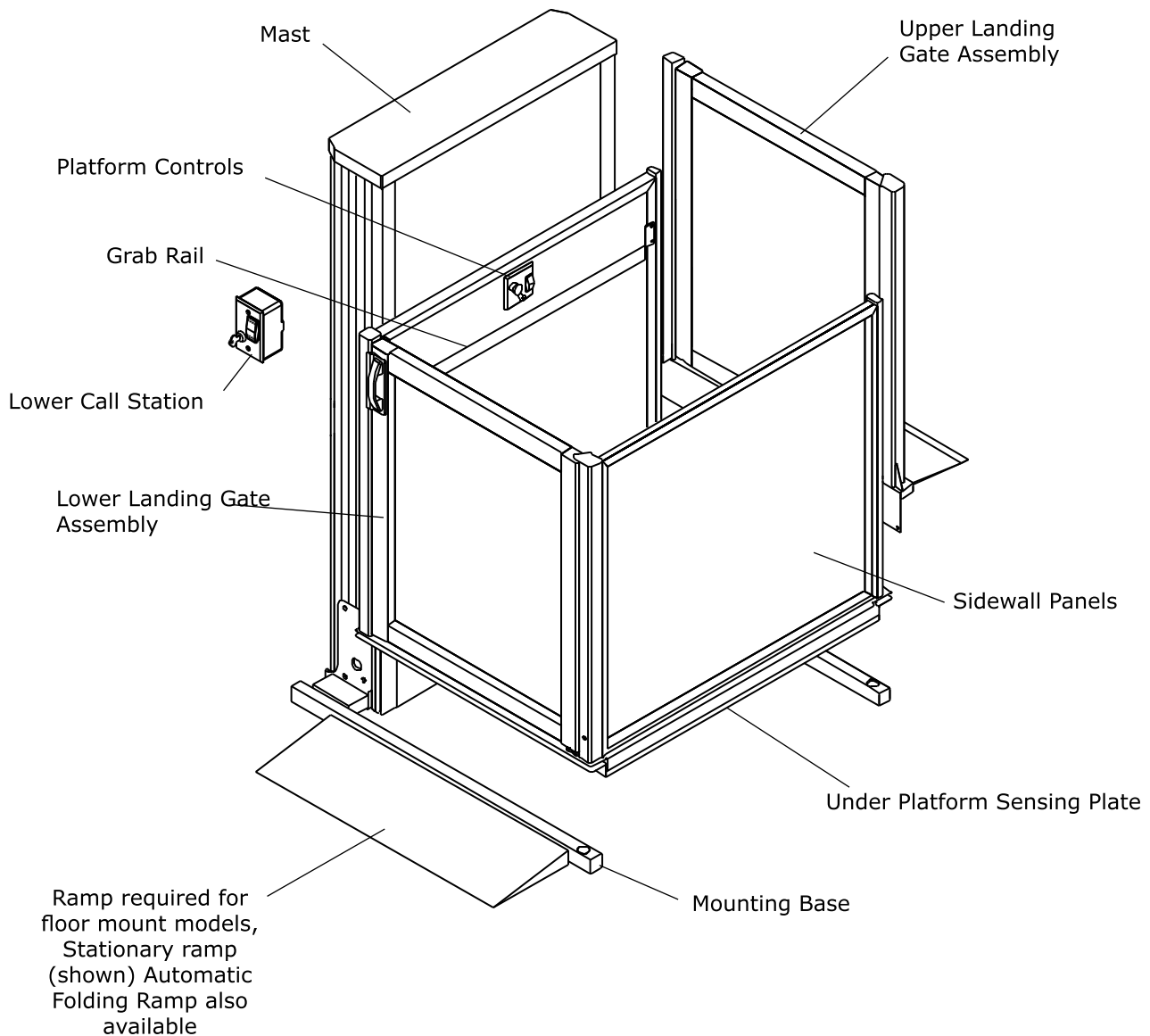

Standard Straight-Through Configuration

Platforms

The Genesis OPAL has 3 platform sizes to meet your requirements.

(1) Standard (2) Mid-Size (3) Large

All three of these platforms have a **rated load of 340 kg. (750 lbs.)**. For the convenience of the passenger, a grab rail and the platform controls are mounted on the side wall that is adjacent to the mast.

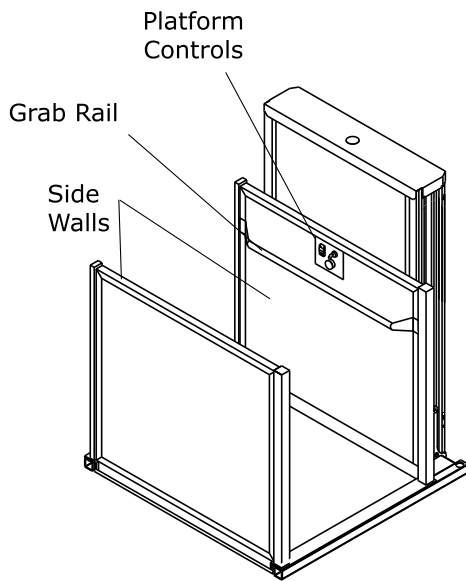

Straight Through Platform

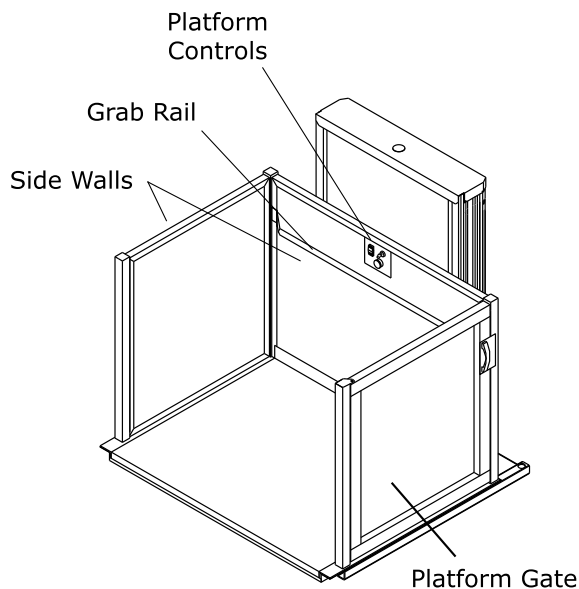

90° Platform

Platform Controls

The platform controls consist of a **Constant Pressure Directional Control Switch**, an **Audible Illuminated Emergency Stop/Alarm Switch** and can be equipped with a **Key Switch** (optional).

Illuminated and tactile constant pressure buttons are available (optional).

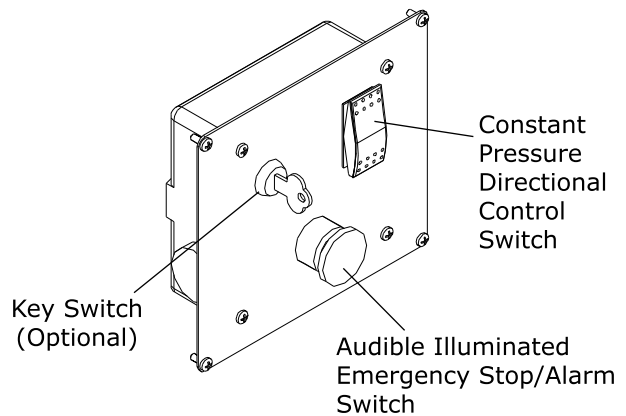

Platform Controls

Platform Clear Dimensions

Clear inside dimensions vary depending on entry/exit configuration (placement of side walls) and platform size. Please refer to the chart below for the actual **clear** inside platform dimensions.

Straight Through Configuration

Platform	Clear Width "A"	Clear Width "B"
Standard	914mm (36")	1242mm (48 7/8")
Mid-Size	914mm (36")	1394mm (54 7/8")
Large	1100mm (43 1/4")	1546mm (60 7/8")

90° Configuration

Platform	Clear Width "A"	Clear Width "B"
Large	1125mm (44 1/4")	1519mm (59 3/4")

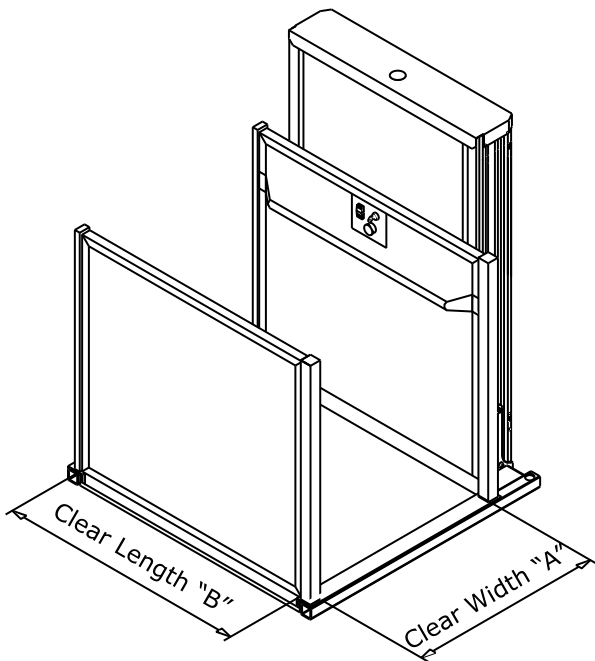

Straight Through Platform

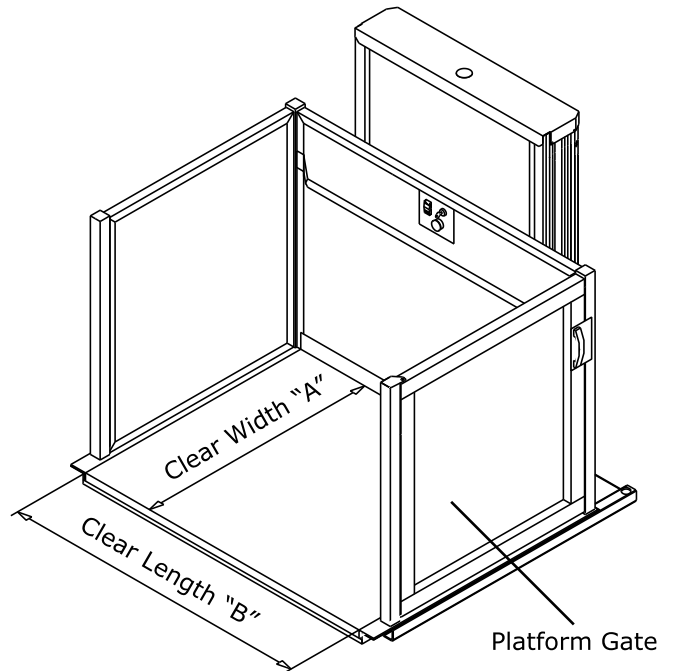

90° Platform

Platform Safety Features

Under Platform Sensing Plate

A pressure sensitive plate is mounted under the platform to detect obstacles underneath the platform. The lift will automatically stop when the under-platform sensing plate encounters an obstruction. The platform may be driven upward to allow the obstruction to be removed.

Non Slip Surface

For the safety of the passengers the steel platform decking is painted with a rough textured non-slip paint.

Pit Switch (optional)

For areas where local codes require a service pit switch, one can be provided at the bottom of the mast. The pit switch shuts off the lift control system while a serviceman is working under the platform.

Base Attachment

The base of the Genesis OPAL is fastened to the floor with lag screws. The floor or pit should be concrete and must be 3500 psi. reinforced, with a minimum 102 mm (4") thickness. If the floor is not concrete, then it must be able to withstand the loads shown on the Opal Loading Diagram which can be found on the Garaventa Architects web site:

www.garaventalift.com/dsgn/Genesis-OPAL-Loading-Diagram.pdf

User Friendly Features

Garaventa PDO - Power Door Operator (optional)

The Garaventa Power Door Operator (PDO) automatically opens the Opal gate when the platform arrives at a landing. When the lift is at the landing, the passenger can press the call station button or gently pull on the gate to activate the door opener. ADA compliant and obstruction sensitive, the gate mounted operator uses low voltage (24VDC) and has all wiring concealed within the lift. Certain applications may limit the use of this operator. Consult your authorized Garaventa representative for which power door operator is appropriate for your application.

Grab Rail (standard)

To aid with loading and unloading a 38mm (1 1/2") grab rail is located at 870mm (34 1/4") above the entire length of the platform decking on the side wall adjacent to the mast.

Offset 'D' Handle (standard)

This option offers a touch of class and improved usability (see image below). This handle is available in a standard clear anodized aluminum look (brushed silver) finish.

Arrival Gong and Digital Floor Display (optional)

Just like an elevator, this is a platform mounted audio and visual platform location and arrival notification. This is a code requirement in some jurisdictions.



Offset 'D' Handle

Footprint and Pit/Runway Dimensions

Straight Through Configuration

Platform Size	Footprint Width	Footprint Length	Pit Width	Pit Length
Standard	1255mm (49 3/8")	1296mm (51")	1319mm (52")	1334mm (52 1/2")
Mid-Size	1255mm (49 3/8")	1448mm (57")	1319mm (52")	1493mm (58 1/2")
Large	1440mm (56 1/2")	1600mm (63")	1508mm (59 3/8")	1645mm (64 1/2")

90° Configuration

Platform Size	Footprint Width	Footprint Length	Pit Width	Pit Length
Large	1440mm (56 1/2")	1600mm (63")	1456mm (57 5/8")	1683mm (66 1/4")

Platform Centerline

Platform Size	Standard	Mid-Size	Large	90° Large
CL	776mm (30 1/2")	776mm (30 1/2")	869mm (34 1/4")	881mm (34 3/4")

Dimensions are provided for reference only. Submittal drawing dimensions should be used for site preparation and construction.

Note: Footprint includes Platform, Mast and Base of Mast.

Pit/Runway dimensions include running clearances to adjacent walls. Mast is against the side of Pit/Runway wall. On non-entry/exit sides, we have added the minimum 64mm (2 1/2") for running clearance required by code. We have added 19mm (3/4") to each entry/exit side as required by code.

Note: If there are no adjacent walls planned, just add 25mm (1") to the Footprint Length and Footprint Width dimensions.

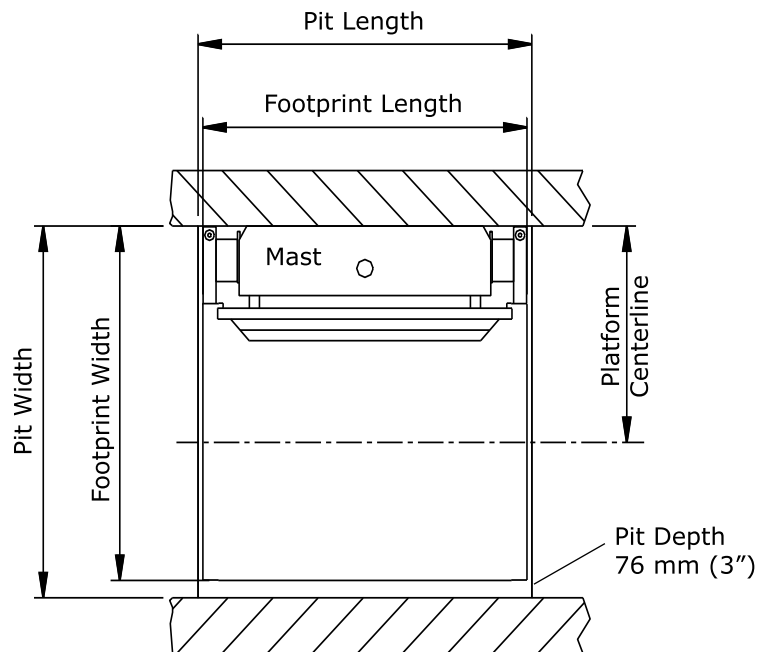

Mast Sizes

The mast size required for a particular site is determined by the vertical distance between the upper and lower landings.

When the site is measured, the lift height "H" is always defined as the distance from the lower finished floor or bottom of pit to the finished floor of the upper landing as shown in the diagram below. If the lift is

to be mounted directly on the surface of the lower landing and an entry ramp (stationary or folding) is used, then "H" equals the elevation change between the upper and lower landings. If the lift is pit mounted, then the measurement "H" is 76mm (3") greater than the elevation change between landings. This measurement is crucial so be certain the height you provide is accurate.

Based on the measured value of "H" the drive mast is selected as follows;

Mast Size	Max. "H" Value	Mast Structure Height	Mast Tieback Height
GVL - 42	1143mm (45")	1737mm (68 3/8")	1572mm (61 7/8")
GVL - 60	1600mm (63")	2194mm (86 3/8")	2029mm (79 7/8")
GVL - 72	1905mm (75")	2498mm (98 3/8")	2333mm (91 7/8")
GVL - 96**	2515mm (99")	3108mm (122 3/8")	2943mm (115 7/8")

The standard width of all masts is 998mm (39 1/4").

** Not compliant to US code, ASME A18.1-2003 Section 2 only allows unenclosed lifts for commercial use for up to 60" of travel.

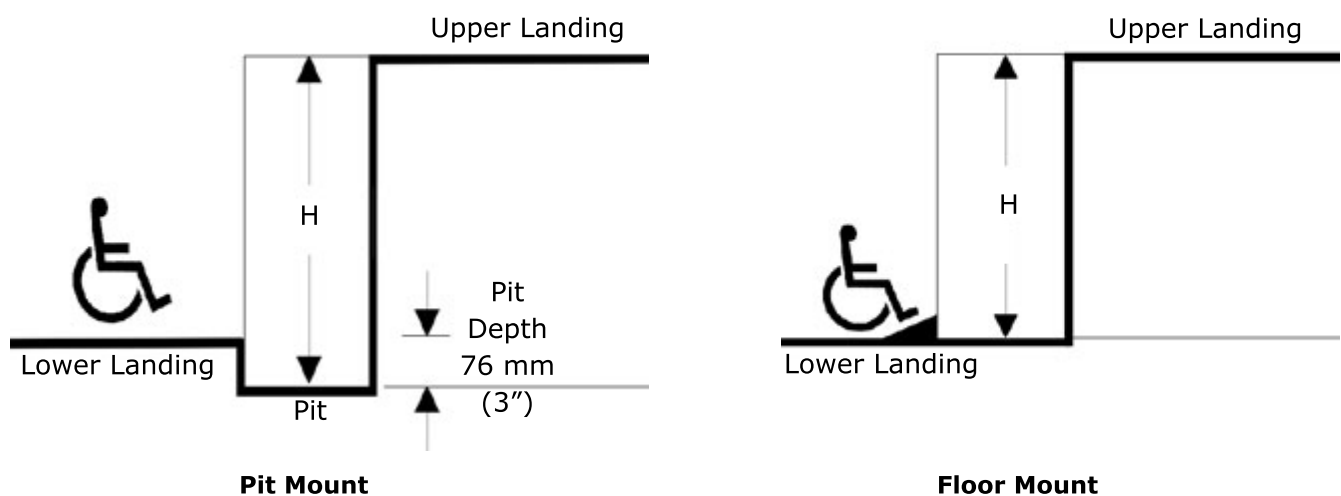

Leadscrew Drive System

Driven by a quiet and reliable 2 H.P. motor attached to a 25mm (1") ACME screw, the OPAL travels between landings at 3 meters (10') per minute.

Mains Power (USA)

The mains power requirement is 120VAC on a dedicated 20 Amp circuit.

Mains Power (International)

208-240 VAC single phase on a dedicated 16 AMP circuit.

Hydraulic Drive System (USA)

Single phase 3 HP (2.2KW), 24 VDC Hydraulic motor, powered by Continuous Mains and equipped with an auxiliary power system travels between landings at 5.2 meters (17 ft.) per minute.

Mains Power (USA)

The mains power requirement is 120VAC on a dedicated 15 Amp circuit.

Mains Power (International)

208-240 VAC single phase on a dedicated 16 AMP circuit.

Drive System Features & Options

Manual Emergency Lowering Handwheel

(Leadscrew Model Only - Standard)

The manual emergency lowering handwheel engages the main drive screw at the top of the mast. The manual emergency lowering handwheel is used to move the platform to the lower landing in the event of a power outage.

Manual Lowering (Hydraulic Model Only - Standard)

The manual lowering device consists of a pull knob mounted in a box on the side of the mast. When used, the platform is lowered to the landing.

Electrical Disconnect (Optional)

A code compliant electrical disconnect is available for both Leadscrew and Hydraulic models. The disconnect shuts off the mains power and the 24V battery operation (Hydraulic only). The disconnect can be shipped loose for wall installation or mounted on an accessible side of the lift mast.

Full Time Battery Operation

(Hydraulic Model Only - Optional)

For applications where the lift will be used infrequently, full time battery operation is available. This simple system is powered by a continuously charged battery pack. ***Choose Continuous Mains for high use applications.**

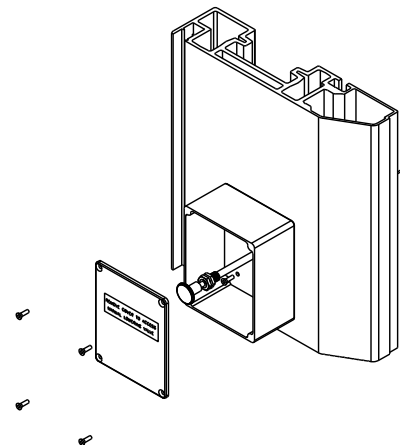

Manual Emergency Lowering Mounted on Mast Rail

Call Stations

The call stations consist of up and down continuous pressure directional control switches and can be fitted with a key switch (optional). The platform is called to the landing by applying constant pressure to the appropriate directional switch. The platform will automatically stop when it has reached that landing.

Lower Call Stations

The lower call station is remotely mounted on a wall.

Upper Call Stations

The upper call station can be mounted in the steel frame of the lift beside the upper gate or can be wall mounted.

Elevator Style Button Package (optional)

Illuminated braille and tactile buttons can be frame mounted or wall mounted in a new wall mount plate. Suitable for indoor or outdoor applications.

Key Switches (optional)

The standard OPAL configuration is for keyless operation. Key switches can be provided for security or to meet local code requirements.

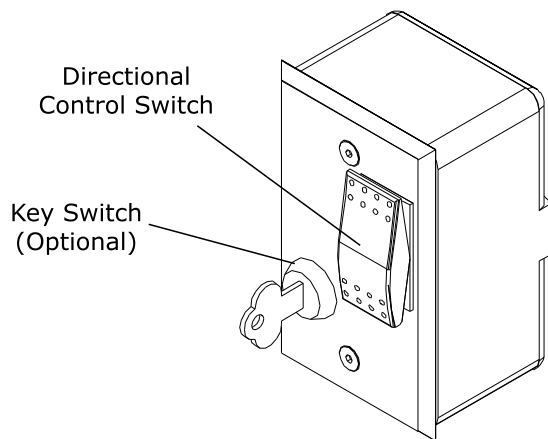

**Wall Mounted Call Station
Used at Lower and/or Upper Landing**

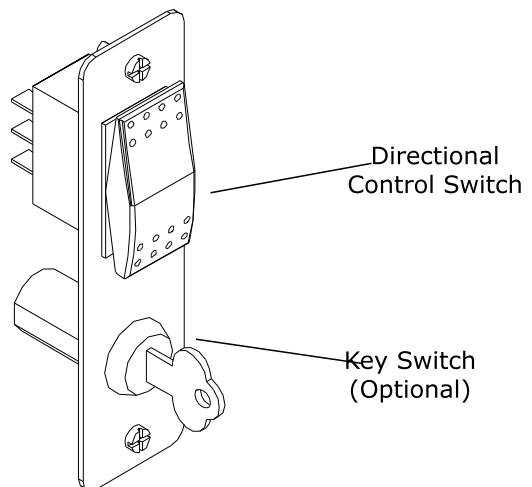

**Frame Mounted Call Station
Used at Upper Landing**

Gates

The lower gate of the Genesis OPAL is mounted onto the platform deck and travels from landing to landing. The upper gate which must be supported at the upper landing creates a safety barrier when the platform is not at the upper landing.

On 90° configurations, the upper gate assembly consists of the wide gate plus a panel that extends the gate assembly to the full length of the platform.

Electro-Mechanical Interlock

The Genesis OPAL is equipped with a durable mechanical interlock system that is electrically monitored. When the platform is not at a landing the mechanical interlock will not allow the gate to be opened.

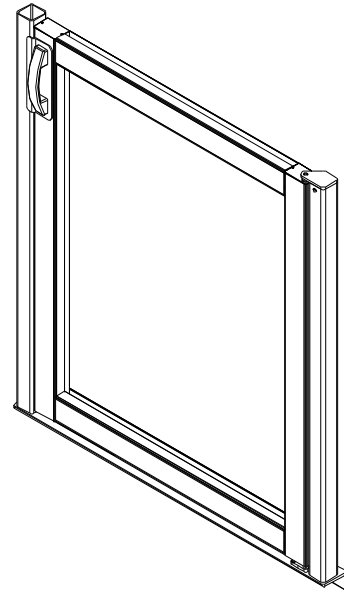

Gate and Frame Assembly

Gate & Gate Assembly Dimensions

Platform Size	Platform Gate Width	Platform Gate Frame Assembly Width	Upper Gate Frame Assembly Width*
Standard	874mm (34 3/8")	976mm (38 1/2")	1054mm (41 1/2")
Mid-Size	874mm (34 3/8")	976mm (38 1/2")	1054mm (41 1/2")
Large	1060mm (41 3/4")	1162mm (45 3/4")	1220mm (48")

Note: All gates are 1070mm (42 1/8") in height. (1100mm (43 1/2") in some jurisdictions) * Upper gate frame assembly must be supported

Gates (Continued)

Gate Positions & Swing Options

The Genesis OPAL is available in two entry/exit configurations. The lift can be supplied as a straight through (180°), or a 90° (left or right exit) lift configuration. With these entry/exit configurations the doors can be hinged on either side of the doorway. This enables the lift to be adapted to the surrounding areas and makes it easier for loading and off loading.

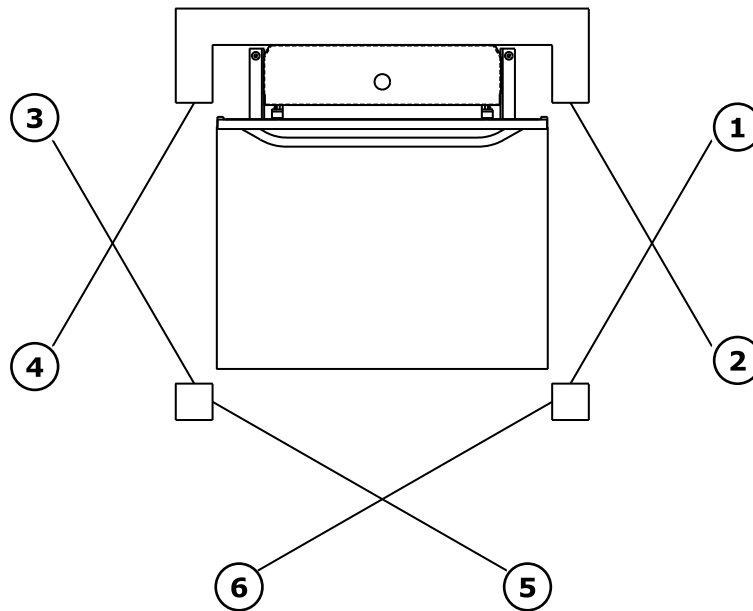

Gate Positions & Swing Options

Ramps

Ramps are an alternative when a 76mm (3") deep pit cannot be provided. There are two styles of ramps to choose from. The first is a **Stationary Ramp** that is fixed to the lower landing. The second is an **Folding Ramp** that is attached to the platform assembly and

travels with the platform. When the platform begins to travel upwards, the ramp folds up automatically clearing the lower landing. For easier entry to the lift, it is recommended that a Power Door Operator is used at a landing where a ramp exists.

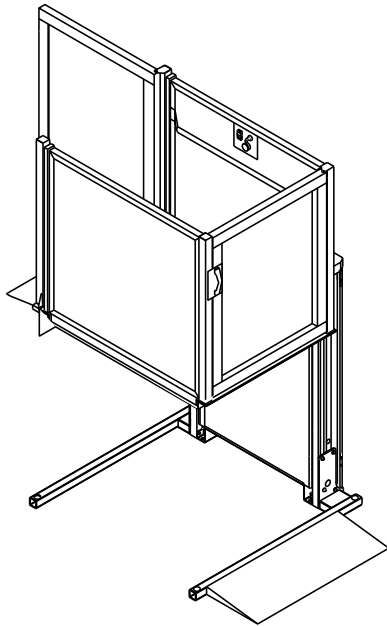

Stationary Ramp

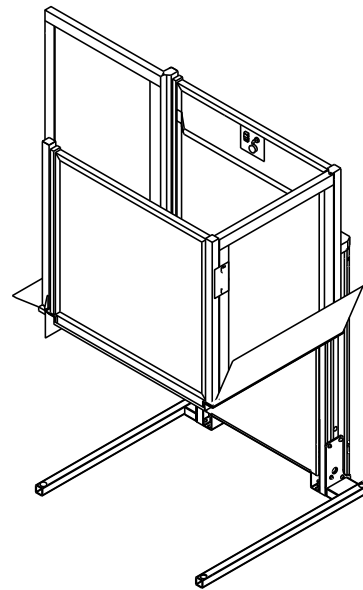

Folding Ramp

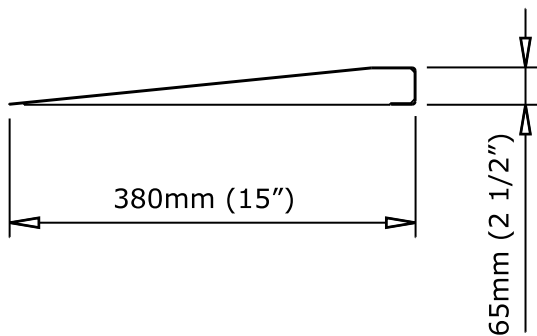

Lower Landing Ramp Dimensions

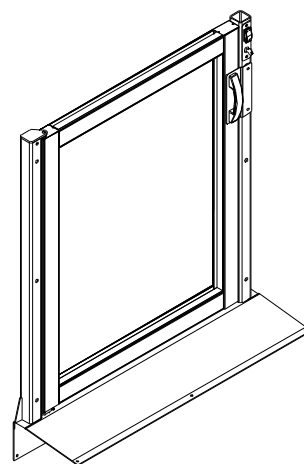

Upper Landing Gate



Creating An Accessible World

 Printed in Canada
15811-N-DP

© Garaventa Lift. As we are continuously improving our products, specifications outlined in this brochure are subject to change without notice.

www.garaventalift.com

Authorized Garaventa Lift Representative